

# SP INVERTER SERIES

## Solar Pump Inverter



### MAIN FEATURES

- Battery-less design 3-phase SOLAR pump inverter (run from Solar or AC directly)
- Built in MPPT solar charger
- High PV Input Voc 800V!
- 2.2KW, 7.5KW, or 11KW models to choose
- Compatible with IEC standard 3-phase asynchronous motor
- Peak 97% efficiency!
- 50Hz or 60Hz supported (programmable)
- Alternative AC Input — compatible with utility or generator
- Auto-restart feature after PV reconnect or AC return
- Automatic derating at high temperature
- Soft start feature available
- Full feature system protection
- RS232 / RS485 monitoring feature
- Large LCD / LED display
- (optional) Monitoring of water tank level through input dry contact signal

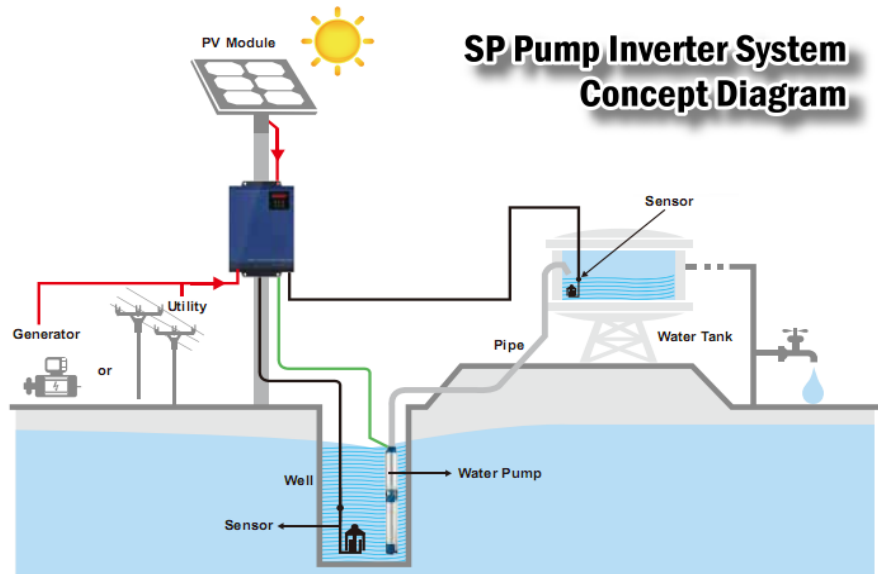

SP Solar Pump Inverter	SP-2.2K	SP-7.5K	SP-11K
<b>INPUT POWER</b>			
Max PV array	3,500W	12,000W	17,600W
Max PV Input Voc	800Vdc		
MPPT Range	500 - 600Vdc		
Startup Voltage	350Vdc		
Max Input PV current	4.3A	14.5A	21.3A
(Optional) AC Input Power	4,000VA	11,000VA	16,500VA
(Optional) AC Input Voltage	380, 400, 415, 440VAC (3 phase)		
(Optional) AC Input Max Current	5.8A	20.5A	27A
<b>OUTPUT POWER</b>			
Power Phase	3 Phase only		
Output Voltage	380, 400, 415, 440VAC (3 phase)		
Max Output Power	2,200W	7,500W	11,000W
Peak Efficiency	97%		
Max Output Current	5A	17A	26A
Motor Type	3-Phase asynchronous motor		
Output Frequency	50Hz / 60Hz, adjustable		
<b>ENVIRONMENTAL / MECHANICAL SPECIFICATIONS</b>			
Protections	Over/Under-Voltage, Over Current, Over Temp, Short Circuit, Surge		
Communication	RS-232, RS-485		
Operating Temp.	-20°C~ 45°C (100% load, power derate >45°C)		
Operating Humidity	0~95%RH Non-Condensing		
Dimension	110*230*330mm		
Weight/Packing	5.5Kg	6Kg	6.5Kg